



Series RBXc
"ANTI - SHOCK"
AIR RELEASE & VACUUM BREAK VALVES

CATALOGUE INDEX

CONTENT	PAGE
OPERATION	1-2
RECOMMENDED INSTALLATION ARRANGEMENTS	3
COMPONENT DESCRIPTION & MATERIAL SPECIFICATIONS DN25 (1") & DN50 (2") - Screwed	4
COMPONENT DESCRIPTION & MATERIAL SPECIFICATIONS DN80 (3") & DN200 (8") - Flanged	5
COMPONENT DESCRIPTION & MATERIAL SPECIFICATIONS DN250 (10") & DN300 (12") - Flanged	6
GENERAL SPECIFICATIONS DN25 (1") & DN50 (2") - Screwed	7
GENERAL SPECIFICATIONS DN80 (3") & DN200 (8") - Flanged	8
GENERAL SPECIFICATIONS DN250 (10") & DN300 (12") - Flanged	9
SELECTION & POSITIONING - SERIES RBXc	10-12
SURGE & WATERHAMMER PROTECTION	13-14
SMALL ORIFICE DISCHARGE PERFORMANCE	15
WHY VENT-O-MAT SERIES RBXc	16
PURCHASE SPECIFICATIONS	17
ORDERING GUIDE & TEST SPECIFICATION	18

Series RBXc OPERATION

PRE NOTES:

1. VENTING OF A FILLING PIPELINE:

The operation of a kinetic air release valve is such that fast approaching water is almost instantaneously halted by the valve's closure without the shock cushioning benefit of any retained air in the pipeline. Consequently a transient pressure rise or shock of potentially damaging proportions can be generated in a pipeline system, even at normal filling rates.

In addition to venting through the Large Orifice (1) when water approach velocities are sub critical, the Vent-O-Mat series RBXc air release valves feature an automatic 'Anti-Shock' Orifice (8) device that serves to decelerate water approaching at excessive speed, thereby limiting pressure rise to a maximum of 1.5 x rated working pressure of the valve.

2. SURGE ALLEVIATION - PIPELINE PRESSURIZED:

In instances where a pipeline experiences water column separation due to pump stoppage, high shock pressures can be generated when the separated water column rejoins.

The Vent-O-Mat series RBXc takes in air through the unobstructed large orifice when water column separation occurs, but controls the discharge of air through the 'Anti-Shock' Orifice as the separated column commences to rejoin. The rejoining impact velocity is thereby sufficiently reduced to prevent an unacceptably high surge pressure in the system. In the same way the series RBXc valve prevents high surge pressures resulting from liquid oscillation in a pipeline.

3. PRESSURIZED AIR RELEASE FROM A FULL PIPELINE:

Effective discharge by the valve of pressurized air depends on the existence of a 'CRITICAL RELATIONSHIP' between the area of the Small Orifice (7) and the mass of Control Float (4), i.e. the mass of the float must be greater than the force created by the working pressure acting on the orifice area. If the float is relatively too light or the orifice area relatively too great, the float will be held against the orifice, even when not buoyed, and air discharge will not be effected.

To ensure that the correct 'CRITICAL RELATIONSHIP' exists the requisite 'DROP TEST' described under TEST SPECIFICATION on page 18 must be applied to any air release valve which is intended for discharge of pressurized air.

4. OPERATION OF DN250, DN300 & DN400 MAY DIFFER FROM BELOW.

VENTING OF A FILLING PIPELINE (SUB CRITICAL WATER APPROACH VELOCITY)

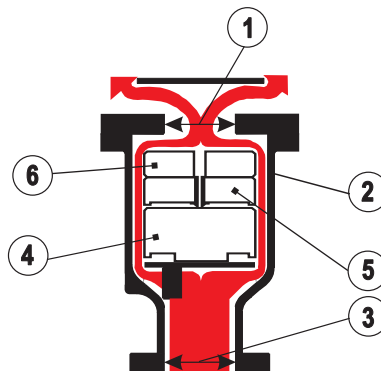

Air enters Orifice (3), travels through the annular space between the cylindrical floats (4), (5), and (6) and the valve Chamber Barrel (2) and discharges from the Large Orifice (1) into atmosphere.

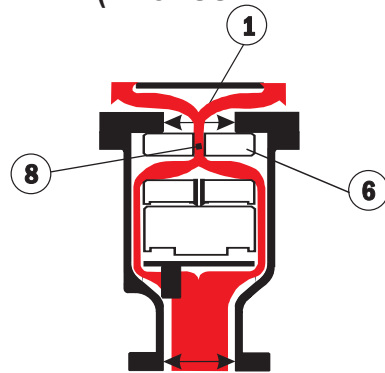
Series RBXc**OPERATION****VENTING OF A FILLING PIPELINE (EXCESSIVE WATER APPROACH VELOCITY)**

In reaction to increased air flow, Float (6) closes Large Orifice (1) and air is forced through the Anti Shock Orifice (8) resulting in deceleration of the approaching water due to the resistance of rising air pressure in the valve.

Attention is drawn to Pre Note 1 and 2 on page 1.

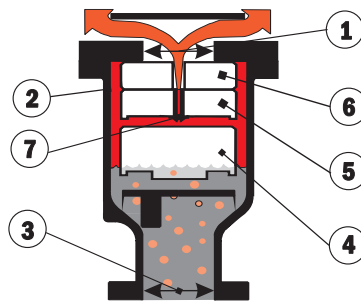
PRESSURISED AIR RELEASE FROM A FULL PIPELINE

Subsequent to the filling of a pipeline, liquid enters the valve Barrel Chamber (2) and the Floats (4), (5) and (6) are buoyed so that the Large Orifice (1) is closed by Float (6). The valve will then become internally pressurised. A minimal working pressure of < 0.5 bar (7.3 psi) acting on the relatively large area of the Orifice (1) will lock Float (6) into the closed position across the Large Orifice (1).

Disentrained air rises through the liquid and accumulates in the valve chamber. When the volume of air is sufficient to displace the liquid, Float (4) will no longer be buoyant and will gravitate downwards thereby opening the Small Orifice (7) and allowing accumulated air to be discharged into atmosphere. As air is discharged the liquid raises the Float (4) and re-seals the Small Orifice (7) and prevents the escape of liquid.

Specific attention is drawn to pre note 3 on page 1.

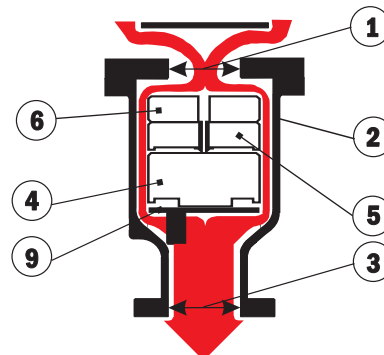
VACUUM RELIEF (AIR INTAKE) OF A DRAINING PIPELINE

Simultaneous drainage of liquid from Valve Chamber (2) causes Floats (4), (5) and (6) to gravitate downwards into the Baffle Plate (9), thereby allowing atmospheric air through the valve to rapidly displace draining liquid in the pipeline and prevent potentially damaging internal negative pressure..

RECOMMENDED INSTALLATION ARRANGEMENTS

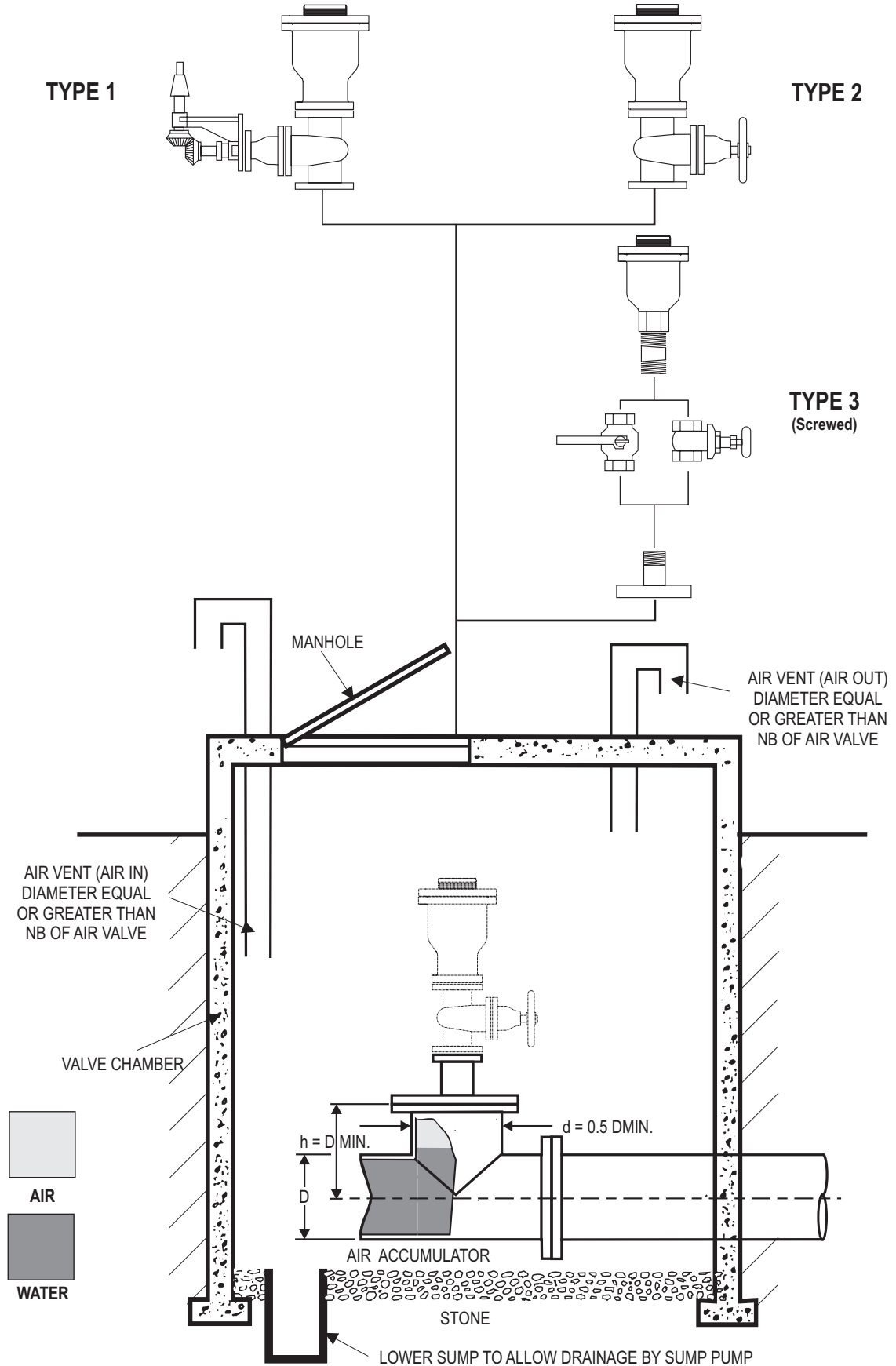

COMPONENT DESCRIPTION & MATERIAL SPECIFICATION SCREWED - DN50 (2")

Type:

Series RBXc - Double Orifice (Small & Large Orifice)
with Anti Shock Orifice Mechanism

End Connection:

Screwed BSP (ISO R7)/ NPT Female

Nominal Sizes:

DN25 (1")
DN50 (2")

Model No's:

RBXc 2511 & 2521

Pressure Ratings:

PN25 (363 psi) ANSI #300

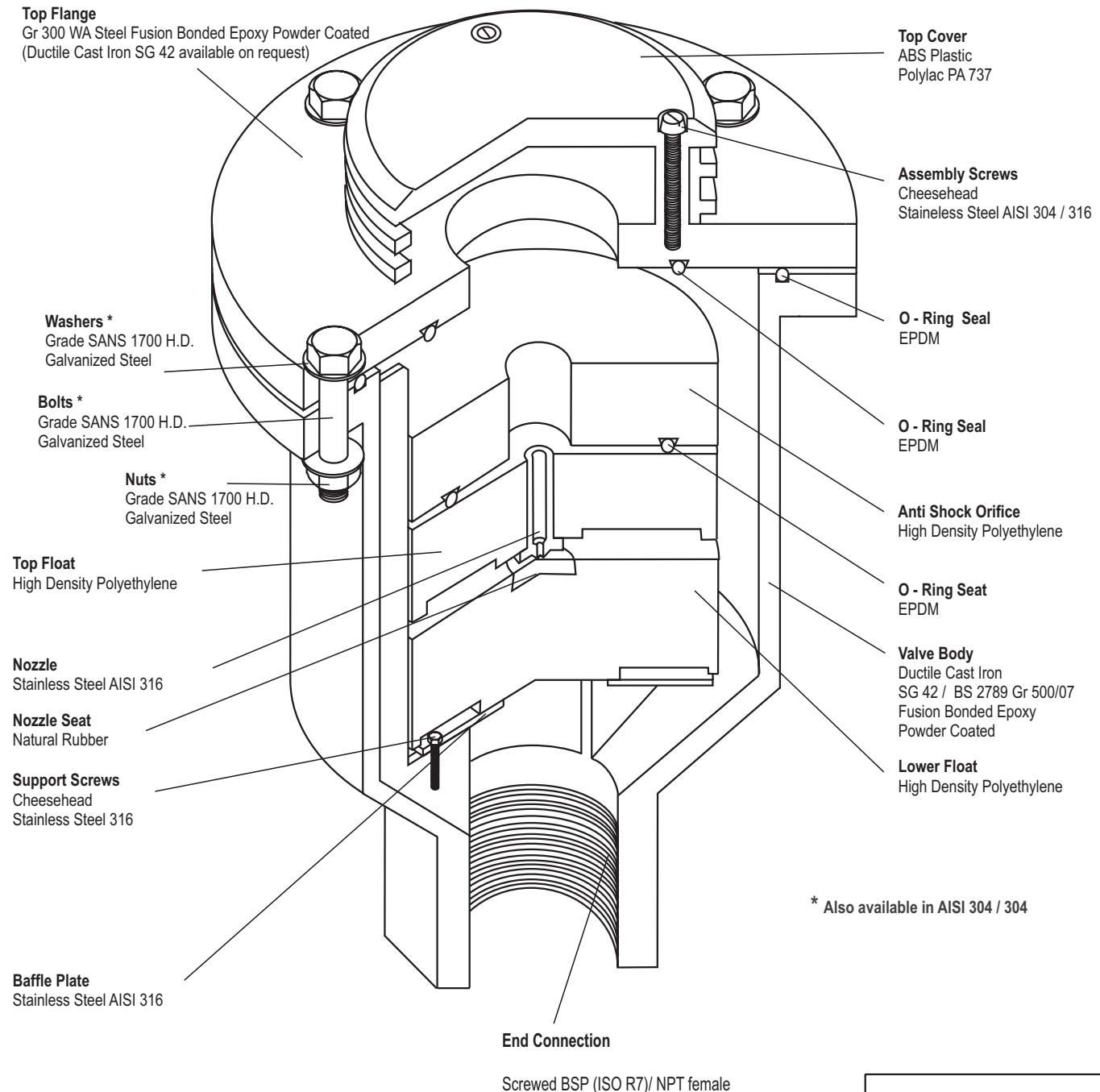

COMPONENT DESCRIPTION & MATERIAL SPECIFICATION FLANGED - DN50 (2") TO DN200 (8")

Type:
Series RBXc - Double Orifice (Small & Large Orifice)
with Anti Shock Orifice Mechanism

End Connection:
Flanged

Nominal Sizes:
DN50 (2")
Dn50 (3")
DN100 (4")
DN150 (6")
DN200 (8")

Model No's:
RBXc 1601 & 1631
RBXc 2511 & 2521

Pressure Ratings:
PN16 (232 psi) ANSI #150
PN25 (363 psi) ANSI #300

Top Flange
Gr 300 WA Steel Fusion Bonded Epoxy Powder Coated
(Ductile Cast Iron SG 42 available on request)

Top Cover
ABS Plastic
Polylac PA 737

Assembly Screws
Cheesehead
Stainless Steel AISI 304 / 316

Bolts *
Grade SANS 1700 H.D.
Galvanized Steel

O - Ring Seal
EPDM

Washers*
Grade SANS 1700 H.D.
Galvanized Steel

O - Ring Seal
EPDM

Nuts *
Grade SANS 1700 H.D.
Galvanized Steel

Anti Shock Orifice
High Density Polyethylene

Top Float
High Density Polyethylene

O - Ring Seal
EPDM

Nozzle
Stainless Steel AISI 316

Valve Body
Cast Ductile Iron
SG 42 / BS 2789 Gr 500/07
Fusion Bonded Epoxy
Powder Coated

Nozzle Seat
Natural Rubber

Lower Float
High Density Polyethylene

Support Screws
Cheesehead
Stainless Steel AISI 316

Assembly Screws
Cheesehead
Stainless Steel AISI 316

Baffle Plate
50mm (2") - 100mm (4")
Stainless Steel AISI 316

Retainer Plate
Stainless Steel AISI 316

150mm (6") - 200mm (8")
Ductile Iron Sg42 /
BS 2789 Grade 500/07
Fusion Bonded Epoxy
Powder Coated

* Also available in AISI 304 / 304

COMPONENT DESCRIPTION & MATERIAL SPECIFICATION FLANGED - DN250 (10") & DN300 (12")

Type:
Series RBXc - Double Orifice (Small & Large Orifice)
with Anti Shock Orifice Mechanism

End Connection:
Flanged

Nominal Sizes:
DN250 (10")
DN300 (12")

Model No's:
RBXc 1601 & 1631
RBXc 2501 & 2531

Pressure Ratings:
PN16 (232 psi) ANSI #150
PN25 (363 psi) ANSI #300

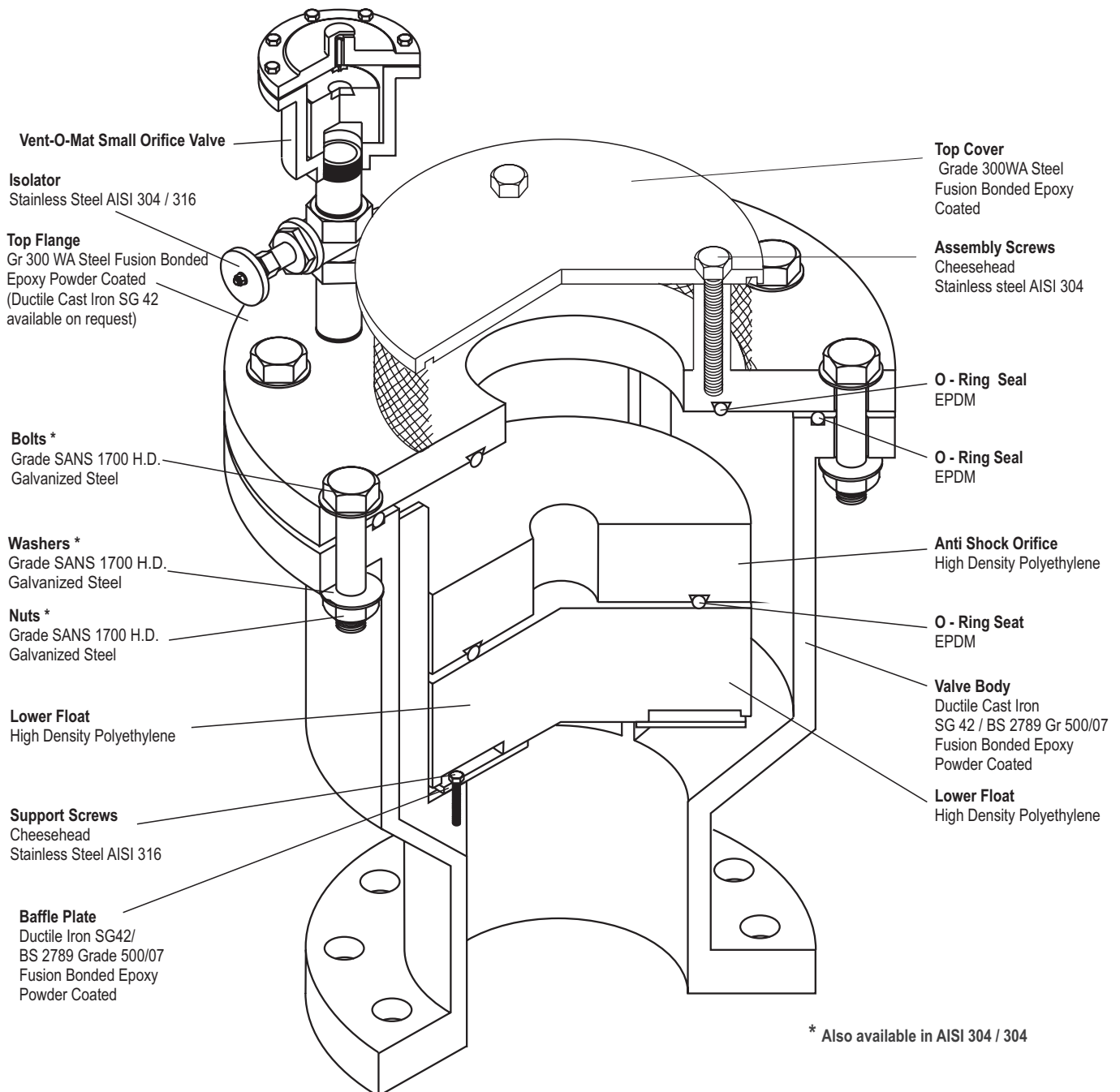

GENERAL SPECIFICATIONS SCREWED - DN50 (2")

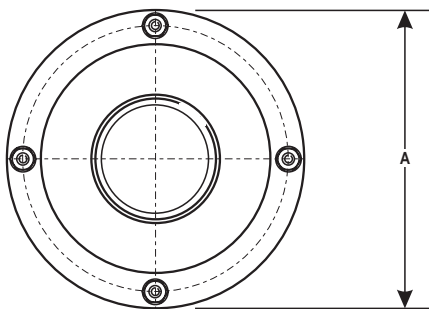
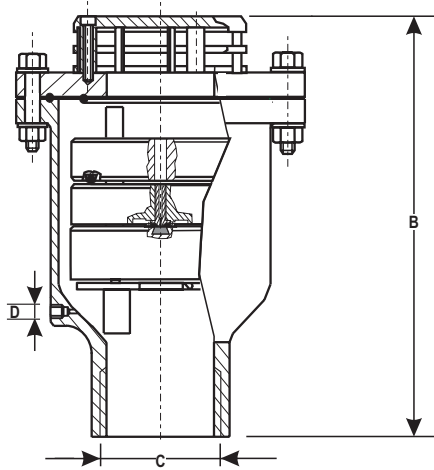
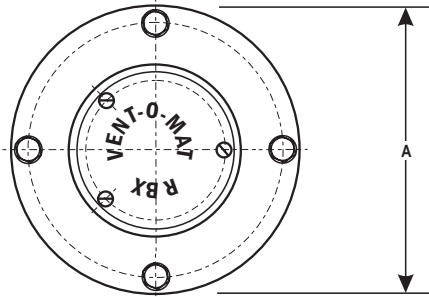

Type:

Double Orifice (Small & Large Orifice) with Anti Shock Orifice mechanism.

End Connection:

Screwed BSP/ NPT female

Nominal Sizes:

DN50 (2")

Model No's:

RBXc 2511 & 2521

Pressure Ratings bar (psi):

25 bar (363 psi)

Operating Pressure Range - bar (psi):

	Min	Max.
25 bar (363 psi)	0.5 (7.2)	25 (363)

Operating Temperature Range:

0 °C (35 °F) to 85 °C (185 °F)

Acceptable Media:

Potable or strained raw water.

Function:

- i) High volume air discharge - pipeline filling.
- ii) High volume air intake - pipeline draining
- iii) Pressurized air discharge - pipeline filled.
- iv) Surge dampening - high velocity air discharge, water column separation & liquid oscillation.

Materials of Construction: - see page 4

Installation: - see page 3

Standard Factory Tests:

- i) Hydrostatic - 1.5 x max. rated working pressure
- ii) Low head leak - 0.5 bar (7.2 psi)
- iii) Small orifice function at max. rated working pressure (minimum 1 valve in 10).

OVERALL DIMENSIONS & WEIGHTS

DN mm in.	MODEL No.	PRESSURE RATING	A		B		C	D <small>OPTIONAL 1/4 BSP/NPT BLEED PORT</small>	WEIGHT	
			mm	in.	mm	in.			kg.	lbs
50 2"	050 RBXc 2511 & 2521	PN25 (363 psi) ANSI #300	219	8 5/8	295	11 5/8	2" BSP/NPT	9.8	21.5	

Dn25 (1") Available on request.

GENERAL SPECIFICATIONS FLANGED - DN50 (2") TO DN200 (8")

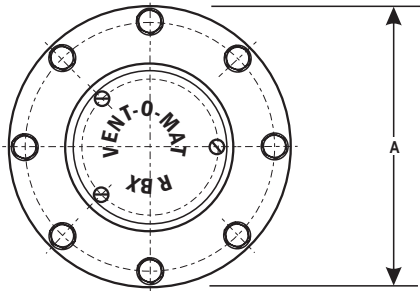

Type:

Double Orifice (Small & Large Orifice) with Anti Shock Orifice mechanism.

End Connection:

Flange for Alignment to;
BS EN1515 PN 16 & PN 25
SABS 1123 - Tables 1600/3 & 2500/3
ANSI B16.5 Class 150 & Class 300

Nominal Sizes:

DN50 (3") & DN200 (8")

Model No's:

RBXc 1601 _____ 16 bar (232 psi)
RBXc 2501 _____ 25 bar (363 psi)

Pressure Ratings bar (psi):

Operating Pressure Range - bar (psi):

	Min	Max.
16 bar (232 psi)	0.5 (7.2)	16 (232)
25 bar (363 psi)	0.5 (7.2)	25 (363)

Operating Temperature Range:

0 °C (35 °F) to 85 °C (185 °F)

Acceptable Media:

Potable or strained raw water.

Function:

- i) High volume air discharge - pipeline filling.
- ii) High volume air intake - pipeline draining
- iii) Pressurized air discharge - pipeline filled.
- iv) Surge dampening - high velocity air discharge, water column separation & liquid oscillation.

Materials of Construction: - see page 5

Installation: - see page 3

Standard Factory Tests:

- i) Hydrostatic - 1.5 x max. rated working pressure
- ii) Low head leak - 0.5 bar (7.2 psi)
- iii) Small orifice function at max. rated working pressure (minimum 1 valve in 10).

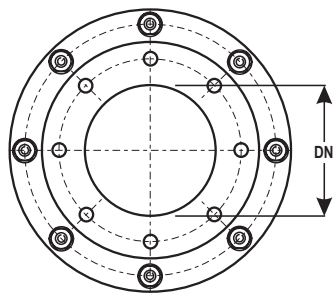
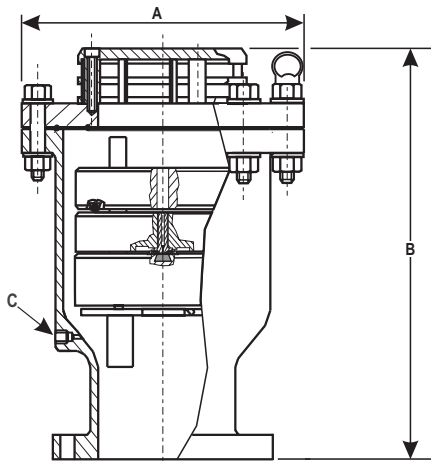

OVERALL DIMENSIONS & WEIGHTS

DN mm in	MODEL NUMBER	PRESSURE RATING	A		B		D	MASS	
			mm	in	mm	in		±kg	±lbs
050 2	050RBXc1631	PN16 (232 psi) ASME B16.5 #150	182	7.17	295	11.61	OPTIONAL 15mm (1/4") BSP/NPT BLEED PORT	17	37.48
050 2	050RBXc2531	PN25 (363 psi) ASME B16.5 #300	182	7.17	298	11.73		18	39.68
080 3	080RBXc1631	PN16 (232 psi) ASME B16.5 #150	200	7.87	355	13.98		25	55.12
080 3	080RBXc2531	PN25 (363 psi) ASME B16.5 #300	200	7.87	360	14.17		28	61.73
100 4	100RBXc1631	PN16 (232 psi) ASME B16.5 #150	270	10.63	402	15.83		43	94.80
100 4	100RBXc2501	PN25 (363 psi) ASME B16.5 #300	270	10.63	410	16.14		47	103.62
150 6	150RBXc1631	PN16 (232 psi) ASME B16.5 #150	374	14.72	517	20.35		88	194.01
150 6	150RBXc2531	PN25 (363 psi) ASME B16.5 #300	374	14.72	524	20.63		97	213.85
200 8	200RBXc1631	PN16 (232 psi) ASME B16.5 #150	436	17.17	555	21.85		121	266.76
200 8	200RBXc2531	PN25 (363 psi) ASME B16.5 #300	436	17.17	567	22.32		134	295.42

GENERAL SPECIFICATIONS FLANGED - DN250 (10") & DN300 (12")

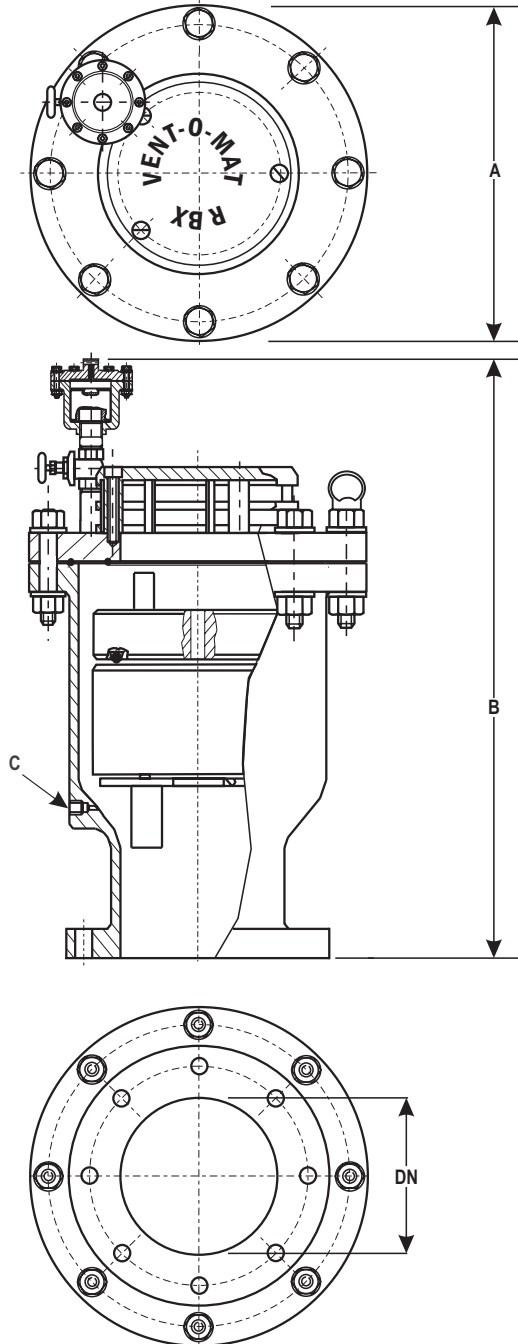

Type:

Double Orifice (Small & Large Orifice) with Anti Shock Orifice mechanism.

End Connection:

Flange for Alignment to;
BS EN1515 PN 16 & PN 25
SABS 1123 - Tables 1600/3 & 2500/3
ANSI B16.5 Class 150 & Class 300

Nominal Sizes:

DN250 (10") & DN300 (12")

Model No's:

RBXc 1601 & 1631 _____ 16 bar (232 psi)

RBXc 2501 & 2531 _____ 25 bar (363 psi)

Pressure Ratings bar (psi):

Operating Pressure Range - bar (psi):

	Min	Max.
16 bar (232 psi)	0.5 (7.2)	16 (232)
25 bar (363 psi)	0.5 (7.2)	25 (363)

Operating Temperature Range:

0 °C (35 °F) to 85 °C (185 °F)

Acceptable Media:

Potable or strained raw water.

Function:

- i) High volume air discharge - pipeline filling.
- ii) High volume air intake - pipeline draining
- iii) Pressurized air discharge - pipeline filled.
- iv) Surge dampening - high velocity air discharge, water column separation & liquid oscillation.

Materials of Construction: - see page 6

Installation: - see page 3

Standard Factory Tests:

- i) Hydrostatic - 1.5 x max. rated working pressure
- ii) Low head leak - 0.5 bar (7.2 psi)
- iii) Small orifice function at max. rated working pressure (minimum 1 valve in 10).

OVERALL DIMENSIONS & WEIGHTS

DN		MODEL NUMBER	PRESSURE RATING	A		B		D	MASS	
mm	in			mm	in	mm	in		±kg	±lbs
250	10	250RBXc1631	PN16 (232 psi) ASME B16.5 #150	586	23.07	816	32.13	OPTIONAL 15mm (1/4") BSP/NPT BLEED PORT	231	509.27
250	10	250RBXc2531	PN25 (363 psi) ASME B16.5 #300	586	23.07	834	32.83		245	540.13
300	12	300RBXc1631	PN16 (232 psi) ASME B16.5 #150	685	26.97	890	35.04		331	729.73
300	12	300RBXc2531	PN25 (363 psi) ASME B16.5 #300	685	26.97	909	35.79		354	780.44

SELECTION & POSITIONING

PRE-NOTES

The functional limits of an air valve are governed by three physical laws namely: Joukowski's Equation Boyle's Law and Pascal's Law. Air valve operation however is also dependent on design and internal configuration, and can vary dramatically from manufacturer's product to manufacturer's product, within the parameters of what is physically possible. The basis of the Vent -O- Mat design is in the understanding of these laws, which have been used to design an air release and vacuum break valve that provides the optimum usable safe performance relative to all functions. The following summary is a general guideline of factors to consider when sizing air valves.

Sizing for Vacuum

Calculate necessary valve orifice sizes independently for each apex point.

Determine the smallest air release and vacuum break valve capable of admitting air into the pipeline equal to the potential water flow out of the pipeline whilst not exceeding a differential pressure that would put the pipeline and gasket joints at risk. We recommend 0.35 bar (5psi) Dp for steel pipe or lower if GRP, uPVC or HDPE pipe is being utilised. This exercise is simplified on pages 11 and 12 of this catalogue. Be cautious of air valve designs with spherical floats as a low pressure zone is created above the float which causes it to partially close off the large orifice during air intake.

Note that vacuum protection is dependent on valve size selection and orifice size relative to the nominal size of the valve. In sizing air valves be cautious of designs with restricted orifice diameters, i.e., orifice diameters that are smaller than the nominal size of the valve, as this could lead to insufficient vacuum protection and pipe collapse if not accommodated for. Vent -O- Mat large orifice diameters and flow path through the ale is equal to the nominal size of the valve e.g. a DN100 (4") ale has a 100mm (4") orifice. This ensures the least possible resistance to the intake of air and consequently the least possible negative pressure within a draining pipeline.

Sizing for Discharge

If a Vent -O- Mat air valve is sized correctly for air intake, discharge should not be a factor in sizing as all air will be discharged through the large orifice or "Anti-Shock" orifice (refer to RBXc operation on pages 1 and 2 of this catalogue). If this information is used for the sizing of air valves other than Vent-O-Mat recommend that ale be selected that is capable of discharging air equal to the filling rate, whilst not exceeding a differential of 0.05 bar (0.7) psi across the large orifice in order to prevent pressure surge and water hammer.

Pressurized Air Discharge

Effective discharge by an air release and vacuum break vale of pressurized air depends on the existence of a "Critical Relationship" between the area of the small orifice and the mass of the control float, i.e., the mass of the float must be greater than the force created by the working pressure acting on the orifice area. If the float is relatively too light or the orifice area relatively too great, the float will be held against the orifice even when not buoyed, and air discharge will not take place.

Surge Alleviation

It is imperative, due to the unpredictable nature of pipeline operation, that every air release and vacuum break valve should as standard, incorporate a surge and water hammer alleviation mechanism. This mechanism should only be activated in the instance of high velocity air discharge or pump trip (where the separated liquid columns rejoin at excessive velocities). The alleviation of surge and/or water hammer must be achieved by deceleration of the approaching liquid prior to valve closure (see operation of RBXc on pages 1 and 2 of this catalogue). Relief mechanisms that act subsequent to valve closure cannot react in the low millisecond time span required and are therefore unacceptable (refer to pages 13 and 14 of this catalogue).

Kindly contact the manufacturer for a free Air valve Sizing Disc and a copy of the Vent -O- Mat publication; "Air Valve Technology Reviewed", which gives a comprehensive guideline on air valve sizing as well as an in-depth look at air valve research and development over the past 35 years. Vent-O-Mat in addition provides assistance on air valve sizing and positioning.

SELECTION & POSITIONING

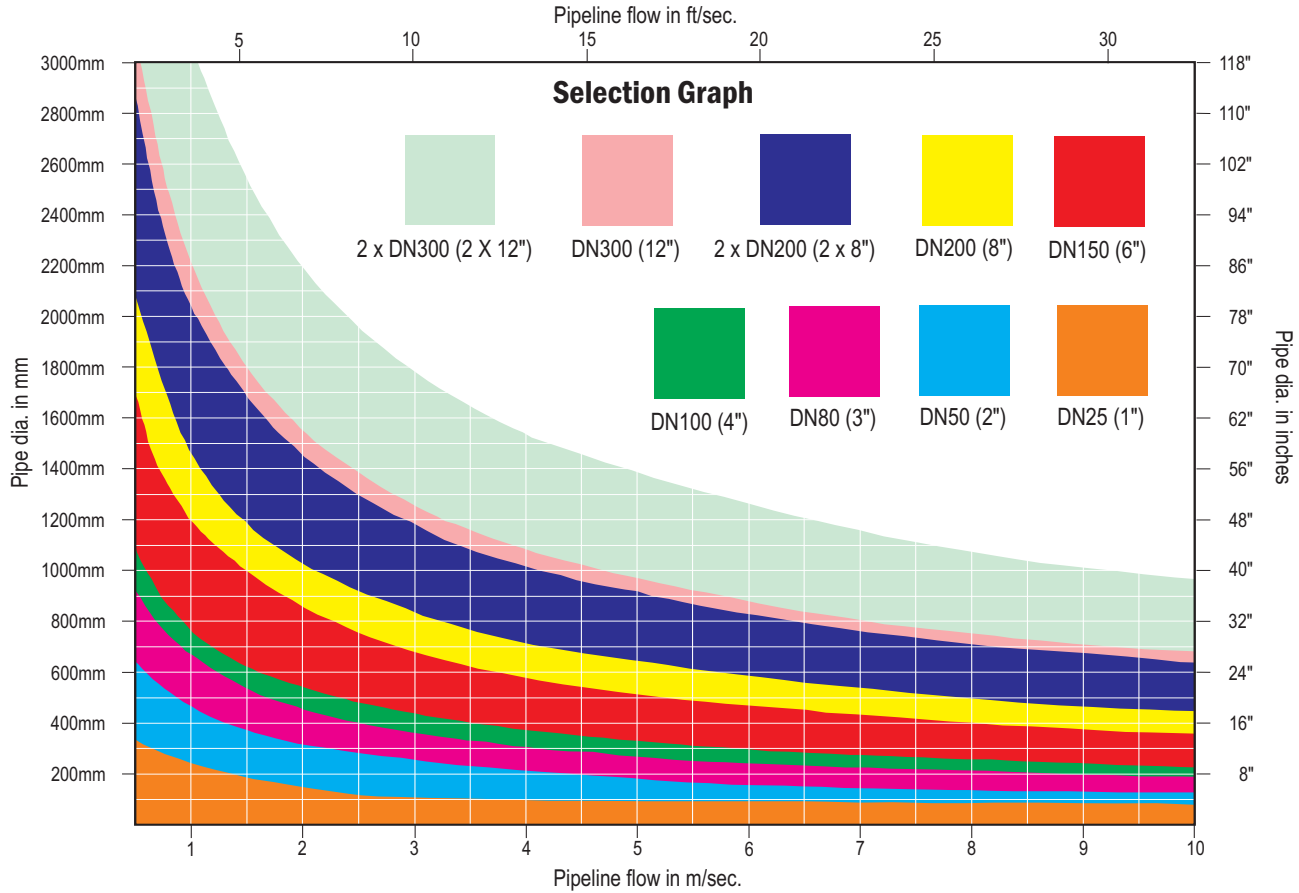

Pipe Dia		Pipeline Velocity in Metres per sec.																			
inches	mm	0.5	1	1.5	2	2.5	3	3.5	4	4.5	5	5.5	6	6.5	7	7.5	8	8.5	9	9.5	10
4	100	5	9	14	18	23	28	32	37	41	46	51	55	60	64	69	74	78	83	87	92
6	150	10	20	31	41	51	61	72	82	92	102	113	123	133	143	154	164	174	184	195	205
8	200	18	35	53	70	88	105	123	141	158	176	193	211	229	246	264	281	299	316	334	352
10	250	27	55	82	110	137	165	192	220	247	275	302	330	357	385	412	440	467	495	522	550
12	300	39	78	117	156	194	233	272	311	350	389	428	467	506	545	583	622	661	700	739	778
14	350	47	94	141	188	235	282	329	376	423	470	517	564	611	658	705	752	799	846	893	940
16	400	62	124	186	247	309	371	433	495	557	618	680	742	804	866	928	989	1051	1113	1175	1237
18	450	79	157	236	315	393	472	551	630	708	787	866	944	1023	1102	1180	1259	1338	1416	1495	1574
20	500	97	194	291	388	485	582	679	776	873	970	1067	1164	1261	1358	1455	1552	1648	1745	1842	1939
22	550	118	236	353	471	589	707	825	942	1060	1178	1296	1414	1532	1649	1767	1885	2003	2121	2238	2356
24	600	140	280	420	560	700	839	979	1119	1259	1399	1539	1679	1819	1959	2099	2239	2379	2518	2658	2798
26	650	163	326	489	653	816	979	1142	1305	1468	1631	1795	1958	2121	2284	2447	2610	2774	2937	3100	3263
28	700	190	380	570	760	949	1139	1329	1519	1709	1899	2089	2279	2468	2658	2848	3038	3228	3418	3608	3798
30	750	219	437	656	875	1093	1312	1530	1749	1968	2186	2405	2624	2842	3061	3280	3498	3717	3935	4154	4373
32	800	249	499	748	998	1247	1497	1746	1995	2245	2494	2744	2993	3242	3492	3741	3991	4240	4490	4739	4988
34	850	282	564	847	1129	1411	1693	1976	2258	2540	2822	3105	3387	3669	3951	4233	4516	4798	5080	5362	5645
36	900	317	634	951	1268	1585	1902	2219	2537	2854	3171	3488	3805	4122	4439	4756	5073	5390	5707	6024	6341
38	950	354	709	1063	1418	1772	2126	2481	2835	3190	3544	3899	4253	4607	4962	5316	5671	6025	6379	6734	7088
40	1000	393	785	1178	1571	1963	2356	2749	3142	3534	3927	4320	4712	5105	5498	5890	6283	6676	7069	7461	7854
44	1100	475	950	1425	1901	2376	2851	3326	3801	4276	4752	5227	5702	6177	6652	7127	7603	8078	8553	9028	9503
48	1200	565	1131	1696	2262	2827	3393	3958	4524	5089	5655	6220	6786	7351	7917	8482	9048	9613	10179	10744	11310
52	1300	664	1327	1991	2655	3318	3982	4646	5309	5973	6637	7300	7964	8628	9291	9955	10619	11282	11946	12610	13273
56	1400	770	1539	2309	3079	3848	4618	5388	6158	6927	7697	8467	9236	10006	10776	11545	12315	13085	13854	14624	15394
60	1500	884	1767	2651	3534	4418	5301	6185	7069	7952	8836	9719	10603	11486	12370	13254	14137	15021	15904	16788	17671
62	1600	1005	2011	3016	4021	5027	6032	7037	8042	9048	10053	11058	12064	13069	14074	15080	16085	17090	18096	19101	20106
66	1700	1135	2270	3405	4540	5675	6809	7944	9079	10214	11349	12484	13619	14754	15889	17024	18158	19293	20428	21563	22698
70	1800	1272	2545	3817	5089	6362	7634	8906	10179	11451	12723	13996	15268	16540	17813	19085	20358	21630	22902	24175	25447
74	1900	1418	2835	4253	5671	7088	8506	9924	11341	12759	14176	15594	17012	18429	19847	21265	22682	24100	25518	26935	28353
78	2000	1571	3142	4712	6283	7854	9425	10996	12566	14137	15708	17279	18850	20420	21991	23562	25133	26704	28274	29845	31416
82	2100	1732	3464	5195	6927	8659	10391	12123	13854	15586	17318	19050	20782	22513	24245	25977	27709	29441	31172	32904	34636
86	2200	1901	3801	5702	7603	9503	11404	13305	15205	17106	19007	20907	22808	24709	26609	28510	30411	32312	34212	36113	38013
90	2300	2077	4155	6232	8310	10387	12464	14542	16619	18696	20774	22851	24929	27006	29083	31161	33238	35315	37393	39470	41548
94	2400	2262	4524	6786	9048	11310	13572	15834	18096	20358	22619	24881	27143	29405	31667	33929	36191	38453	40715	42977	45239
98	2500	2454	4909	7363	9817	12272	14726	17181	19635	22089	24544	26998	29452	31907	34361	36816	39270	41724	44179	46633	49087
102	2600	2655	5309	7964	10619	13273	15928	18583	21237	23892	26546	29201	31856	34510	37165	39820	42474	45129	47784	50438	53093
106	2700	2863	5726	8588	11451	14314	17177	20039	22902	25765	28628	31491	34353	37216	40079	42942	45804	48667	51530	54393	57256
110	2800	3079	6158	9236	12315	15394	18473	21551	24630	27709	30788	33866	36945	40024	43103	46181	49260	52339	55418	58496	61575
114	2900	3303	6605	9908	13210	16513	19816	23118	26421	29723	33026	36329	39631	42934	46236	49539	52842	56144	59447	62749	66052
118	3000	3534	7069	10603	14137	17671	21206	24740	28274	31809	35343	38877	42412	45946	49480	53014	56549	60083	63617	67152	70686

Conversion Table / sec. to m/sec. of Pipeline Velocity

information subject to change without prior notice

SELECTION & POSITIONING

VALVE SELECTION FROM GRAPH

All the relevant information has been condensed into one graph to enable valve selection to be simple and easy and at the same time to allow flexibility to the designer to move within certain parameters which eventually allows the most suited and economically viable valve to be selected.

IMPORTANT NOTE: The graph is based on vacuum breaking and limiting vacuum to 3.5 meters (5 psi) below atmospheric. It is not good practice to go below 7 meters (10 psi) absolute (3 meters (4.4 psi) differential in pipeline at sea level). The graph allows for change in altitude and hence change in atmospheric pressure and is based on the assumption that more than one valve per section is used for vacuum protection and venting.

EXAMPLE OF VALVE SIZING (ASSUMING AN INDIVIDUAL SECTION)

A Ø400mm (16") pipeline draining at 409 l/sec (851 scfm) which equates to 3.25 m/sec. (10.66 ft/s), what valve size should be selected?

From the 3.25 m/sec. (10.66 ft/s) point, on the graph on page 11, move vertically until the Ø 400 mm (16") pipe size horizontal line is intersected. This places the intersection point in the operating band of a DN100 (4") Vent -O- Mat RBXc valve. But, if for example, the drainage rate is 433 l/sec. (917 scfm) which equates to 3.5 m/sec. (11.48 ft/s), the valve would be operating close to it's limit and it may be prudent to change to a DN150 (6") Vent-O- Mat RBXc.

ACTUAL SELECTION (GRAVITY OR PUMPED PIPELINES)

Selection is based on the premise that pipelines are generally filled at a slower rate than they are drained, scoured or at which separation occurs (a maximum fill/ drain ratio of 1:1).

1. Determine the maximum drainage rate in m/s (ft/s) either for scouring, pipe rupture or column separation for a particular pipeline section. Conversion from l/sec to m/sec can be done fairly quickly, using the conversion table on page 11.
2. Move vertically on the selection graph (top of page 11) from the m/s (ft/s) point and move horizontally from the pipe size finding the intersecting point.
3. This point should fall within the operating band of a particular valve size. Consideration must be given to the fact that the upper portion of the band approaches - 3.5 meters (- 5psi) and the lower portion - 1 meter (- 1.45 psi) for each valve size, this allows the designer to see at a glance if the valve is too close to it's operating limits and to select the next valve size.

VALVE POSITIONING

1. ON APEX POINTS (relative to hydraulic gradient).
2. 5 METRES (16 FEET) BELOW APEX POINTS FORMED BY INTERSECTION OF PIPELINE AND HYDRAULIC GRADIENT - i.e. where pipeline siphoning over gradient an air release valve positioned on the apex would break the siphon. If positioning on apex is required a modified VENT -O- MAT Series RBXc can be supplied.
3. NEGATIVE BREAKS (increase in downward slope or decrease in upward slope).
4. LONG HORIZONTAL SECTIONS - every 600 metres (1/3 of a mile) maximum.
5. LONG ASCENDING SECTIONS - every 600 metres (1/3 of a mile) maximum.
6. LONG DESCENDING SECTIONS - every 600 metres (1/3 of a mile) maximum.
7. PUMP DISCHARGE (not shown in diagram) - just subsequent to non return valve.
8. BLANK ENDS (not shown in diagram) - where a pipeline is terminated by a blind flange or a valve.

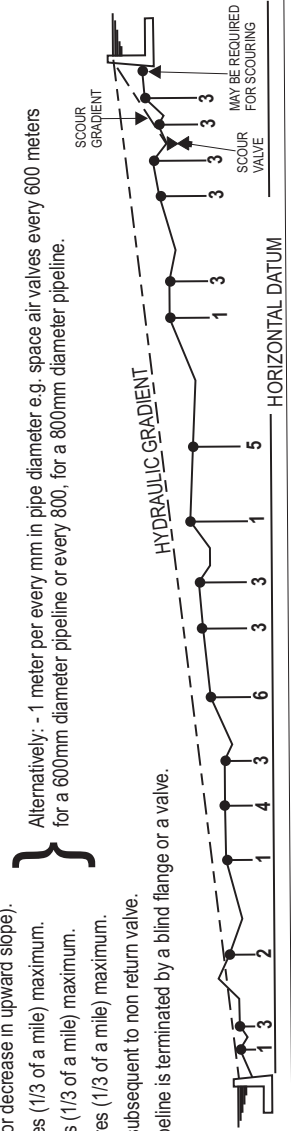

SURGE & WATERHAMMER PROTECTION

Introduction

The Vent-O-Mat Series RBXc "Anti-Shock" air release and vacuum break valve, is the product of extensive research into the development of an efficient, but cost effective solution to surge problems (both mass liquid oscillation and elastic transient phenomena) associated with any operating pipeline. Automatic dampening, relevant to the pipeline's needs is provided by either one of two design features. These special features are unique in a pipeline component of such compact and economic design.

Surge Protection - Initial Filling

The RBXc incorporates the additional floating "Anti-Shock" Orifice which is aerodynamically engineered to throttle air discharge when water approach velocity would otherwise become too great and induce an unacceptable pressure rise. The air throttling action increases resistance to the flow of the approaching water which consequently decelerates to a velocity which reduces the pressure rise when the valve closes (see operation of valve on pages 1 & 2). Vent-O-Mat series RBXc is an essential precaution for pipeline priming.

Surge Protection - Pump Trip Conditions

In instances where a pipeline experiences water column separation due to pump stoppage, high shock pressures can be generated when the separated water column rejoins.

The Vent-O-Mat series RBXc takes in air through the unobstructed large orifice when water column separation occurs, but controls the discharge of air through the "Anti-Shock" Orifice as the separated column commences to rejoin. The rejoining impact velocity is thereby considerably reduced to alleviate high surge pressures in the system (see operation of valve on pages 1 & 2).

Other surge control measures may, dependant on pipeline profile, diameter and operating conditions, be needed to provide the primary surge alleviation function with the Vent-O-Mat air-valves forming an integral and valuable addition in a combined strategy for further reducing surge pressures. The benefit of the "Anti-Shock" Orifice can be readily demonstrated by suitable surge modeling software.

Surge Protection - Pipeline Operating

The operation of valves and similar flow control devices can cause high-pressure transients in an operating pipeline.

The unique, single chamber design of the Vent-O-Mat series RBXc valve enables a pocket of air to be trapped in the valve chamber. Automatic operation of the small orifice control float regulates the volume of air entrapped.

The volume maintained in the valve will provide a cushioning benefit to the pipeline for short duration transient pressure "spikes". This effect can be modelled by the design engineer using suitable surge software.

SURGE & WATERHAMMER PROTECTION

Computer Modelling

The effectiveness of Vent-O-Mat series RBXc has been substantiated by independent third party testing and by thousands of applications globally. Effective computer modelling, based on practical tests, has been ensured in the well-known and respected commercially available **SURGE 5.3** surge analysis software programme. Accurate results are also obtained by other commercially available surge analysis software programmes such as FLOWMASTER and TRANSAM.

Holistic Surge & Water Hammer Protection

Vent-O-Mat forms an integral part of a well planned, holistic surge protection strategy that should, according to application needs and financial constraints, include surge vessels, check valves, control valves and/or any other equipment needed to alleviate unacceptable surge behaviour.

Technical and Financial Benefits

The Vent-O-Mat series RBXc valve offers definite financial and technical advantages when incorporated as part of a holistic surge protection strategy. This includes:

1. Improved alleviation of surge behaviour including reduction of:
 - Surge pressure magnitudes by slowing surge velocities
 - Duration of oscillation following a pump trip, as the air-valve continuously absorbs and dissipates the energies of the surge.
2. Potential for reduction in size and/or quantity of conventional surge protection devices such as surge vessels etc.
3. Automatic protection during initial filling when most surge protection devices are not operational.
4. Holistic protection as each air valve installed has design features to automatically damp surges.
5. The valve is virtually maintenance free.

Service

Vent-O-Mat is committed to finding the most cost effective and efficient solution to pipeline complexities. Services include air valve sizing and positioning and assistance to consulting engineers on defining appropriate surge and water hammer protection strategies. Vent-O-Mat has built a sound relationship with many international consulting firms and has gained global recognition for selling solutions!

SMALL ORIFICE DISCHARGE PERFORMANCE

Type:
Series RBXc - Double Orifice (Small & Large Orifice)
with 'Anti Shock Orifice' Mechanism

Model No's:
RBXc 1601/ 1631
RBXc 2511/ 2521/ 2501/ 2531

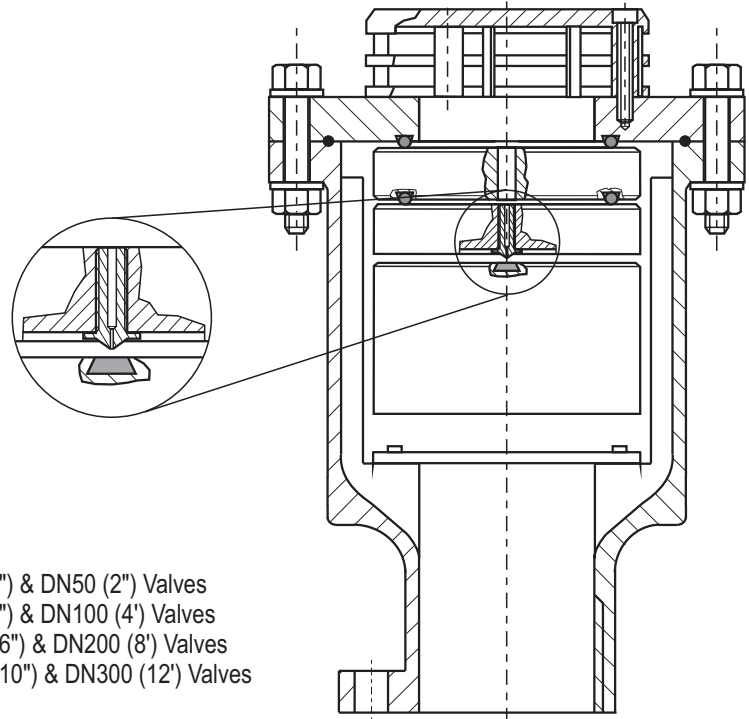

- \varnothing 1.2 mm (o.Ø. 047") small orifice - DN25 (1") & DN50 (2") Valves
- \varnothing 1.5 mm (o.Ø. 059") small orifice - DN80 (3") & DN100 (4") Valves
- \varnothing 2.4 mm (o.Ø. 094") small orifice - DN150 (6") & DN200 (8") Valves
- \varnothing 3.2 mm (o.Ø. 125") small orifice - DN250 (10") & DN300 (12") Valves

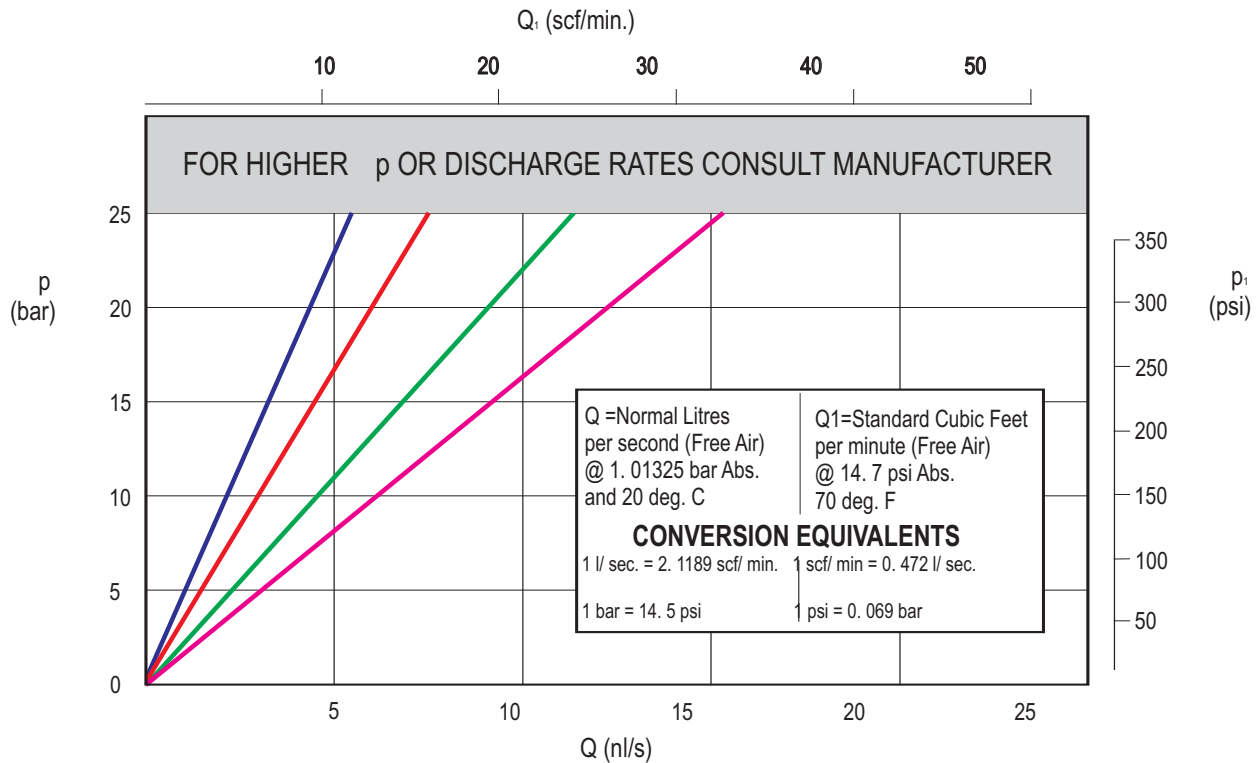

Why ?

- **"ANTI - SHOCK" - "ANTI - SURGE"** - The RBXc is the only air release valve available that is supplied as standard with a mechanism which operates automatically to prevent pipeline damage from the high induced pressure transients associated with high velocity air discharge. Surge resulting from liquid column separation and liquid oscillation is dramatically reduced as an automatic function of this mechanism.

- **PERFORMANCE** - The RBXc has been designed and developed to provide the optimum usable and safe performance relative to all functions. Selection data has been substantiated through CSIR and other testing and can therefore, be confidently referenced.

- **QUALITY** - The RBXc economically offers the highest quality construction and materials available in an air release and vacuum break valve. Stringent manufacturing and test procedures are maintained to ensure the best possible service and reliability is given by every valve produced.

- **SERVICEABILITY** - The RBXc design facilitates extreme ease of service and maintenance. Components are in corrosion free materials to allow problem free disassembly and reassembly even after many years of operation. All maintenance spares are replaceable without special tools or skills.

- **VACUUM BREAK** - The RBXc series large orifice diameters equal the nominal size of the valve, i.e., a 200mm (8") valve has a 200mm (8") orifice. This ensures the least possible resistance to the intake of air and consequently the least possible negative pressure within a draining pipeline.

- **COMPACTNESS** - Although extremely robust the RBXc valve's lightweight and compact construction offers handling transport and installation advantages.

- **BACK UP** - Vent -O- Mat provides highly committed customer orientated sales, service, spares and technical back up - TRY US!!!

PURCHASE SPECIFICATION**VENT -O- MAT MODEL NO.**

Page 7 - Series RBXc - DN25 (1") or DN50 (2") with BSP (ISO R7) or NPT, Screwed Female Connection.

Page 8 - Series RBXc - DN80 (3") to DN200 (8") Flanged Connection.

Page 9 - Series RBXc - DN250 (10") to DN300 (12") Flanged Connection.

CONSTRUCTION & DESIGN

The air release & vacuum break valve shall be of the compact single chamber design with solid cylindrical H.D.P.E. control floats housed in a tubular ductile cast iron body, epoxy powder coated to 300 microns, secured by means of stainless steel 304/316 fasteners.

The valve shall have an integral 'Anti - Shock' Orifice mechanism which shall operate automatically to limit transient pressure rise or shock induced by closure to 1.5 x valve rated working pressure.

The intake orifice area shall be equal to the nominal size of the valve i.e., a 150mm (6") valve shall have a 150mm (6") intake orifice.

Large orifice sealing shall be effected by the flat face of the control float seating against a nitrile/EPDM rubber 'O' ring housed in a dovetail groove circumferentially surrounding the orifice.

Discharge of pressurized air shall be controlled by the seating & unseating of a small orifice nozzle on a natural rubber seal affixed into the control float. The nozzle shall have a flat seating land surrounding the orifice so that the damage to the rubber seal is prevented.

The valve construction shall be proportioned with regard to material strength characteristics, so that deformation, leaking or damage of any kind does not occur by submission to twice the designed working pressure.

Connection to the valve inlet shall be facilitated by a screwed BSP (ISO R7) or NPT female end (DN25 (1") & DN50 (2") only) or a flanged end conforming to PN10, 16 & 25 ratings of BS 4504 or SABS 1123 Standards or, ANSI B16. 1 Class 150 and Class 300. **Nuts, bolts, washers, or jointing gaskets shall be excluded.**

Optional: Provision of a 1/4" BSP/ NPT Test/ Bleed Cock.

OPERATION

1. Prior to the ingress of liquid into the valve chamber, as when the pipeline is being filled, valves shall vent through the large orifice when water approach velocities are relative to a transient pressure rise, on valve closure, of < 1.5 x valve rated pressure.

At higher water approach velocities, which have a potential to induce transient pressure rises > 1.5 x valve rated pressure on valve closure, the valve shall automatically discharge air through the Anti Shock Orifice and reduce water approach velocity, so that on closure a maximum transient pressure rise of < 1.5 x valve rated pressure is realised.

2. Valves shall not exhibit leaks or weeping of liquid past the large orifice seal at operating pressures of 0.5 bar (7.3 psi) to 1.5 times rated working pressure.
3. Valves shall respond to the presence of air by discharging it through the small orifice at any pressures within a specified design range, i.e. 0.5 bar (7.3 psi) to 16 bar (232 psi) or 25 bar (363 psi), and shall remain leak tight in the absence of air.
4. Valves shall react immediately to pipeline drainage or water column separation by the full opening of the large orifice so as to allow unobstructed air intake at the lowest possible negative internal pipeline pressure.

ORDERING GUIDE

<p>VALVE SIZE:</p> <p>DN25 (1") - <input type="text" value="025"/></p> <p>DN50 (2") - <input type="text" value="050"/></p> <p>DN80 (3") - <input type="text" value="080"/></p> <p>DN100 (4") - <input type="text" value="100"/></p> <p>DN150 (6") - <input type="text" value="150"/></p> <p>DN200 (8") - <input type="text" value="200"/></p> <p>DN250 (10") - <input type="text" value="250"/></p> <p>DN300 (12") - <input type="text" value="300"/></p> <p>VALVE SERIES No: _____</p> <p>ANTI SHOCK ORIFICE: _____</p> <p>CAST BODY: _____</p>	<p><input type="text" value="050"/> <input type="text" value="RB"/> <input type="text" value="X"/> <input type="text" value="c"/> <input type="text" value="25"/> <input type="text" value="0"/> <input type="text" value="1"/></p>	<p>VALVE TYPE:</p> <p>DOUBLE ACTING <input type="text" value="1"/></p> <p>VALVE END CONNECTION:</p> <p>SCREWED - BSP <input type="text" value="1"/></p> <p>SCREWED - NPT <input type="text" value="2"/></p> <p>FLANGED - BS 4504 OR SABS 1123 <input type="text" value="0"/></p> <p>FLANGED - ANSI B16.5 <input type="text" value="3"/></p> <p>VALVE PRESSURE RATING:</p> <p>PN16 (232 PSI), ANSI#150 <input type="text" value="16"/></p> <p>PN25 (363 PSI), ANSI#300 <input type="text" value="25"/></p>
--	---	--

TEST SPECIFICATION

All air release valves supplied shall be subjected to the following testing procedures in the order laid down:

(A) A high pressure strength and leak test whereby the valve is filled with water and pressurized to 1.5 times the rated working pressure which shall be held for a period of 2 minutes. Any leaking, weeping or sweating shall be reason for rejection.

(B) A low head leak test whereby the valve is filled with water and pressurized to a maximum of 0.5 bar (7.3 psi) using a visible water column connected to the test rig. The valve shall be rejected if leak tightness is not maintained for 2 minutes

(C) Every tenth air release valve of the same size and pressure rating must be subjected to a small orifice function test - "DROP TEST" - whereby the valve is filled with water, pressurized to above rated working pressure and isolated from the test rig by closure of an isolating valve. A chamber in the test rig immediately prior to the isolating valve must be filled with compressed air at a pressure equal to that being maintained in the air release valve. The isolating valve is then opened so as to allow the air to rise in the air release valve without the pressure dropping lower than 2 - 3 bar (29 - 44 psi) above rated working pressure of the air release valve. The "DROP TEST" is then carried out by slowly bleeding off the pressure through a suitable cock until rated working pressure is reached and the float drops away from the orifice to allow discharge. Failure of the air release valve to function in the manner described will be reason for rejection.

On request the manufacturer shall provide batch certificates of test compliance which shall be cross referenced to serial numbers indelibly marked onto the identity label of each valve.

IMPORTANT NOTE: It is impossible to inject air into an incompressible liquid, air injection can only be achieved if the liquid can be displaced which implies that the pressure in the test rig must be reduced to atmospheric, and absolutely nothing is proven by discharge through the small orifice of the air release valve at atmospheric pressure. "DROP TESTING" in this manner is not acceptable.

Complete the form below for any additional information and fax/post to:

**DFC Water (Pty) Ltd
P O Box 5064
Benoni South
1502
South Africa**

Tel: (27 11) 748-0200

Fax: (27 11) 421-2749

E Mail: ventomat@dfc.co.za

**Web site: www.ventomat.com
www.dfc.co.za**

Company Name:

Postal Address:

Postal Code: **Country:**

Tel: **Fax:**

Contact Name: **Title:**

Comments:

.....
.....

Products you are interested in:

VENT-O-MAT[®] Series RBX Air Release & Vacuum Break Valves

compact single chamber design with integral "Anti-Shock" surge dampening mechanism in a choice of other materials

VENT-O-MAT[®] Series RGX Air Release & Vacuum Break Valves

compact Stainless Steel single chamber design with integral "Anti-Shock" surge dampening mechanism for sewage applications

VENT-O-MAT[®] Series RC Air Release & Vacuum Break Valves

cast air valve for irrigation and small reticulation systems.

VENT-O-MAT[®] Series RPS Air Release & Vacuum Break Valves

glass reinforced polypropylene CATT air valve for industrial, irrigation and small reticulation systems.

LevelDex[®] High Performance Endline Level Control Valves

end line valve with cushioned closing characteristics for level control in tanks and reservoirs.